

# PIGEON RB400

Pigeon RB400 is an industrial computer designed for control and automation applications, based on the Raspberry Pi Compute Module 5 and running a Linux operating system. It integrates industrial communication and control interfaces, including RS-485, RS-232, Ethernet, CAN, 1-WIRE, digital inputs and digital outputs, and provides one M.2 expansion port for either a PCIe SSD or a USB GSM/LTE modem. The device features a built-in supercapacitor-based UPS that eliminates short power interruptions, enables safe system shutdown, and ensures automatic restart after power restoration under microcontroller supervision.

## FEATURES

### ■ Powered by Raspberry Pi CM 5

Broadcom BCM2712 quad-core 64-bit  
Arm Cortex-A76 (Armv8) SoC @ 2.4 GHz  
2 GB RAM LPDDR4 (optionally up to 16 GB)  
16 GB eMMC Flash (optionally up to 64 GB)

### ■ Wide range of inputs and outputs

8 x digital opto-isolated inputs  
4 x dry contact inputs  
8 x open drain outputs  
4 x analog inputs 0-10 V  
2 x analog outputs 0-10 V

### ■ Rich set of interfaces

2 x RS-485 (optionally up to 4)  
2 x USB 3.0  
USB 2.0  
USB 2.0 device (system flashing)  
RS-232  
Ethernet  
CAN  
1-Wire  
HDMI

### ■ Expansion connector

One M.2 Key B expansion slot, usable either for:  
– PCIe 2.0 SSD modules, or  
– USB-based cellular modem, Nano-SIM

### ■ Real Time Clock

Real Time Clock with battery backup

### ■ Robust design

Two watchdogs  
Complies with EN IEC 61326-1:2021 for basic and industrial electromagnetic environments

### ■ Trusted Platform Module

Compliant to TPM Main Specification, Family 2.0

### ■ Integrated UPS

Supercapacitor based UPS  
Safe shut down procedure  
Power button  
Battery-free, eco-friendly

### ■ Created for long life

Designed, developed and produced in European Union  
No electrolytic capacitors (except UPS supercaps)  
No moving parts

### ■ Low power consumption

High efficiency DC/DC converters  
Peripherals power supply control

### ■ Linux-based system

Small and stable distribution that is fully compatible with official Raspberry Pi OS  
Large community  
Full support for all interfaces

### ■ Easy to program

Installed Linux supports almost all of the major programming languages (C/C++, Python, Java, etc.)  
Open source and commercial software for automation and control systems

### ■ DIN rail enclosure

DIN rail enclosure with the optional wall mount

## APPLICATIONS

- Industrial control and automation systems
- Building automation
- Factory automation
- Industrial control networks

## 1. TECHNICAL SPECIFICATIONS

CPU & memory		
SoC	BCM2712 quad-core 64-bit Arm Cortex-A76 (Armv8) SoC @ 2.4 GHz <sup>1</sup>	
RAM memory	2 GB LPDDR4 (optionally up to 16 GB)	
Flash memory	16 GB eMMC (optionally up to 64 GB)	
Power supply		
Supply voltage	24 V DC (20 ... 32 V)	
Power consumption <sup>2</sup>	Conditions	Supply current @ 24 V
	CPU 100% load	0.35 A
	CPU 1% load	0.13 A
Interfaces & I/O		
	Connector	Quantity
Ethernet 1Gbit	RJ-45	1
RS-485	Terminal blocks	2 / 4 <sup>3</sup>
RS-232	Terminal blocks	1
1-WIRE	Terminal blocks	1
CAN FD	Terminal blocks	1
Digital opto-isolated inputs	Terminal blocks	8
Dry contact inputs	Terminal blocks	4
Open drain outputs	Terminal blocks	8
Analog inputs	Terminal blocks	4
Analog outputs	Terminal blocks	2
M.2 Key B socket (PCIe 2.0 / USB)	M.2 Key B 3042	1
SIM card slot (for M.2 modem)	Nano-SIM slot	1
HDMI 2.0	HDMI Type A	1
USB host 3.0	Type A	2
USB host 2.0	Type A	1
USB device 2.0 (system flashing)	Mini Type B	1
Trusted Platform Module (TPM)	On-board	1
Supercapacitor-based UPS	On-board	1
I/O parameters		
Digital opto-isolated inputs	Low-level input voltage	0 ... +5 V DC
	High-level input voltage	+10 ... +28 V DC
	Isolation voltage	5 kV <sub>RMS</sub>
	Input resistance	>=10 kΩ
Open drain outputs	Maximum current	500 mA
	Maximum voltage	28 V DC
Analog inputs	Voltage Range	0 ... +10 V
	Resolution	10-bit
Analog outputs	Voltage Range	0 ... +10 V
	Resolution	10-bit
5V output DC	Maximum current	0.1 A

1) depending on processor workload, CPU throttling may occur

2) power consumption of devices connected to USB and M.2 is not included

3) optional configuration: four RS-485 ports. In this configuration, the RS-232 interface and dry-contact inputs ID3 and ID4 are not available.

Terminal blocks	Wire range	0.5 - 1.5 mm <sup>2</sup> , 28 -16 AWG
	Torque	0.2 Nm
	Strip length	7 mm
<b>Standards</b>		
EU standard	EN IEC 61326-1:2021	
<b>Environment</b>		
EMC emission	Group 1 class A and class B equipment according to EN IEC 61326-1:2021	
EMC immunity	Industrial electromagnetic environment according to EN IEC 61326-1:2021	
Operating Temperature	0 °C ~ 50 °C	
Operating Relative Humidity	5 ~ 90 %, non-condensing	
Storage Temperature	-25 °C ~ 50 °C	
Protection Rating	IP20	
<b>Miscellaneous</b>		
Watchdog	Two watchdogs: - SoC internal watchdog, - external watchdog connected via GPIO.	
RTC backup battery	CR2032, 3 V	
Dimension	158 x 114 x 59 mm (including terminal blocks connectors)	
Enclosure	Mount	Din-rail, wall mount
	Material	PC/ABS, UL 94 V-0
Weight	300 g	

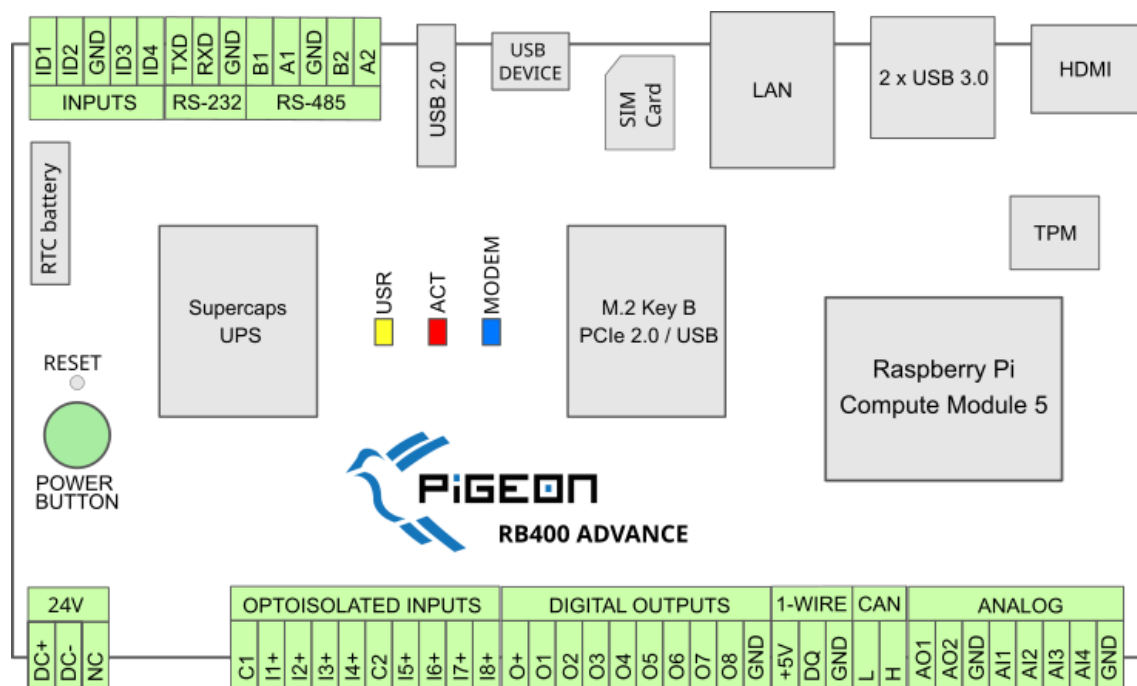

Fig. 1. Connector layout and on-board components

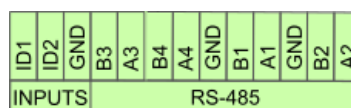

Fig. 2. Connector pinout for optional four-port RS-485 configuration

## 2. CONNECTIONS

### 2.1. POWER SUPPLY

Pigeon RB400 should be connected to AC mains using an AC/DC power supply.  
 Recommended power supply: MEAN WELL model HDR-30-24 (24 V DC, 1.5 A).

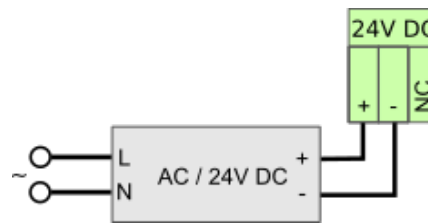

Fig. 3. Power supply connection

### 2.2. DRY CONTACT INPUTS

Fig. 4 shows dry contact inputs connections.

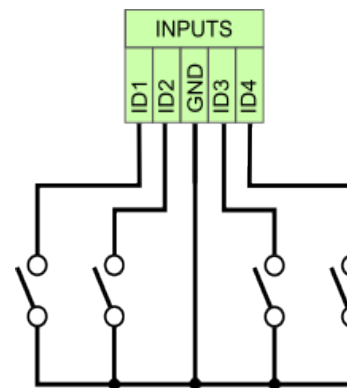

Fig. 4. Dry contact inputs connections

### 2.3. DIGITAL OPTO-ISOLATED INPUTS

Fig. 5 shows digital opto-isolated inputs connections.

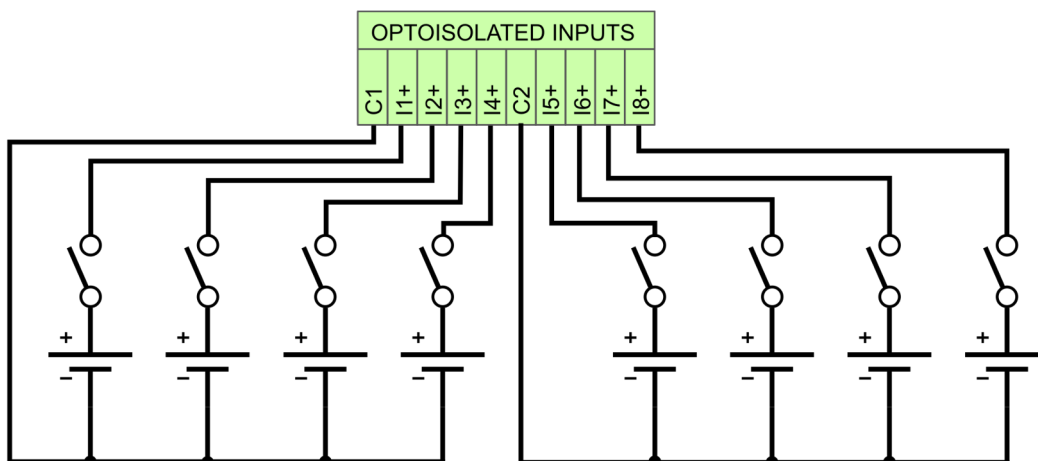

Fig. 5. Digital opto-isolated inputs connections

### 2.4. OPEN DRAIN OUTPUTS

Recommended connection of LED (a) and relays (b,c) to open drain outputs is shown on fig. 6. O+ is terminal to connect + potential when switching inductive load. The internal diodes protect the output transistors from transient voltage peaks (b). In case of long cables to relay, connection with external diode (c) is recommended.

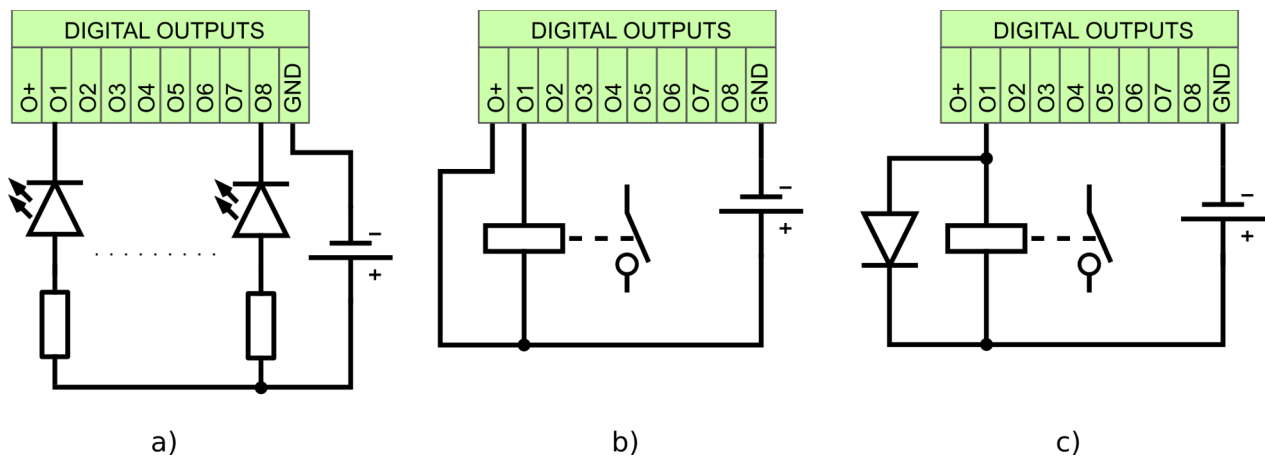

Fig. 6. Example digital outputs connections: (a) LED, (b,c) relay

### 2.5. ANALOG INPUTS AND OUTPUTS

Fig. 7 shows analog inputs and outputs connections.

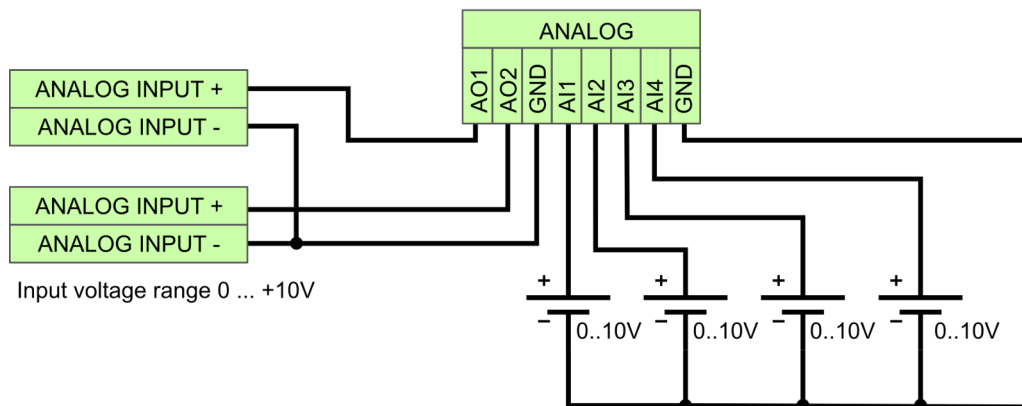

Fig. 7. Analog inputs and outputs connections

### 2.6. CABLE LENGTH

The maximum cable lengths listed below are typical values for reliable operation under standard industrial conditions. Actual achievable cable length may vary depending on cable type, signal quality, grounding, termination, baud rate, and electromagnetic environment.

Connector	Maximum cable length
Power supply	3 m
USB	3 m
HDMI	3 m
1-wire	3 m
Analog inputs/outputs	3 m
Digital inputs/outputs	3 m
RS-232	3 m
Ethernet	30 m
CAN	30 m
RS-485	30 m

### 3. DIMENSIONS

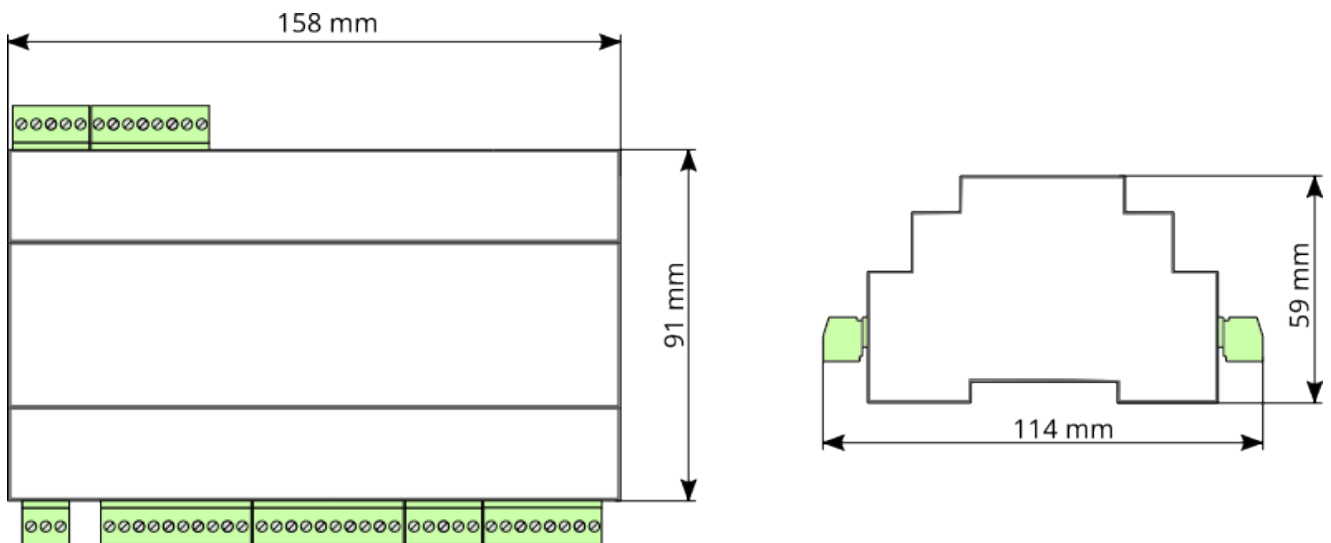

Fig. 8. RB400 dimensions

### 4. ORDER CODES

Order codes	Configuration	Availability
RB400-ADVANCE-CM5002016-2	RAM: 2 GB, eMMC: 16 GB RS-485 ports: 2	Standard production
RB400- <b>OEM</b> -CM50 <b>XX</b> 0 <b>YY</b> - <b>Z</b>	RAM: <b>XX</b> GB eMMC: <b>YY</b> GB RS-485 ports: <b>Z</b> (2 or 4) Version: <b>OEM</b> -specific	On request

#### Notes

- **XX** – RAM size in GB (02, 04, 08, or 16)
- **YY** – eMMC size in GB (16, 32, or 64)
- **Z** – number of RS-485 ports (2 or 4); in the configuration with four RS-485 ports, the RS-232 interface and dry-contact inputs ID3 and ID4 are not available.
- **OEM** - version designed and manufactured for a specific OEM customer.

Product rebranding and hardware customization are available. For details on available options or for further information regarding this device, please contact us.

### 5. ENVIRONMENTAL PROTECTION



This marking on the product, accessories or literature indicates that the product and its electronic accessories should not be disposed of with other household waste. To prevent possible harm to the environment please separate these items from other types of waste and recycle them responsibly to promote the sustainable reuse of material resources.

## 6. SAFETY INSTRUCTIONS

Before you work on any equipment, be aware of the hazards involved with electrical circuitry, and be familiar with standard practices for preventing accidents.

Only qualified personnel should be allowed to install, replace, or service this equipment.

We cannot guarantee that no accidents or damage will occur due to improper use of the device. Please use this product with care and operate at your own risk.

Any external power supply used with Pigeon computers shall comply with relevant regulations and standards applicable in the country of intended use.

This product is intended to be installed indoors. Keep this product away from water, fire, dirt, humidity or hot environments.

Pigeon computers are not authorized for use in safety-critical applications.

In the case of device failure, please disconnect it from power.

All devices used with this product should comply with relevant standards for the country of use and be marked accordingly to ensure that safety and performance requirements are met.

To prevent electrostatic discharge (ESD) from damaging the device, follow proper precautions when setting up the device or handling internal components, particularly when installing modems and SSD drives. A static discharge from a finger or another conductor may damage system boards or other static-sensitive devices.

Always disconnect the device from all power sources before performing any maintenance or service.

Please be aware that models equipped with a built-in Uninterruptible Power Supply (UPS) may retain electrical energy even after the device has been powered off. This residual energy can pose a risk of electric shock. To prevent electric shock, avoid opening the device or touching internal parts.

Do not make any mechanical modifications to the device that are not specified in the datasheet. For example, do not obstruct ventilation openings, as this can lead to overheating and potential equipment failure.



For more information, please visit:

<http://pigeoncomputers.com>

The information in this document is subject to change without notice. Errors excepted

Copyright © Kristech. 2026. All rights reserved

ARM is registered trademark and ARM Limited

Linux is a registered trademark of Linus Torvalds

Raspberry Pi is a trademark of the Raspberry Pi Foundation

All other brand names or product names are the property of their respective holders